

## CVPO-1500BC/5-BECB

Old Type Designation: CV05C-1500PMN

Specifications	
Capacity $C_{max}$ (nominal)	1500 pF
Capacity $C_{min}$ (nominal)	30 pF
Voltage (Peak Test $U_{pt}$ / Peak Working $U_{pw}$ )	5 kV / 3 kV
Capacity Tolerance (linear Range)	10%
Max. Current $I_{max}$ at 13.56 MHz with	105 Arms
Conduction Cooling	30 W
Self Inductance	$\leq 7$ nH
Capacitance per turn	116.7 pF/turn
Torque	$\leq 0.4$ Nm
Net Weight	1.6 kg

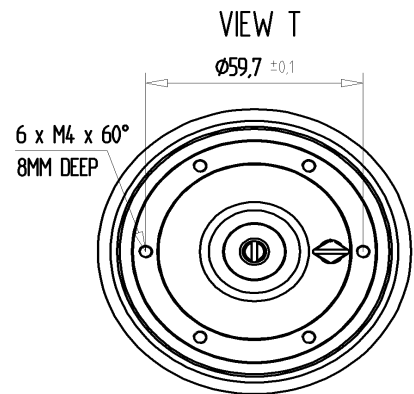
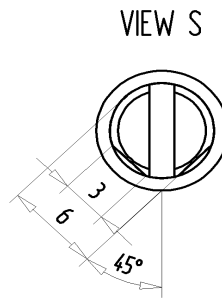
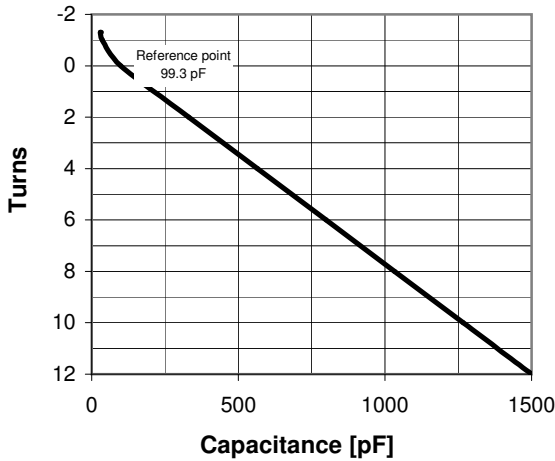
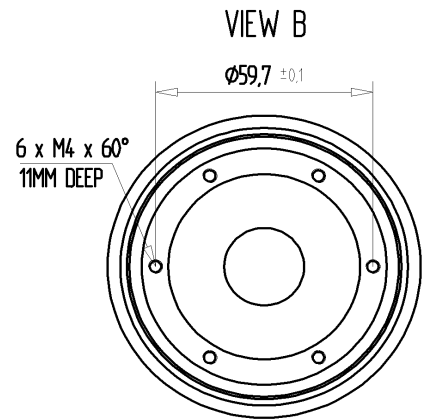

$I_{max}$  at 25°C ambient and 125°C surface temp. for convection and conduction (30 W) cooling

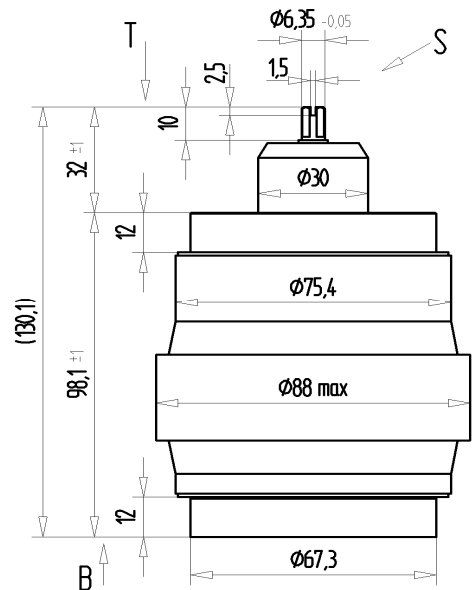
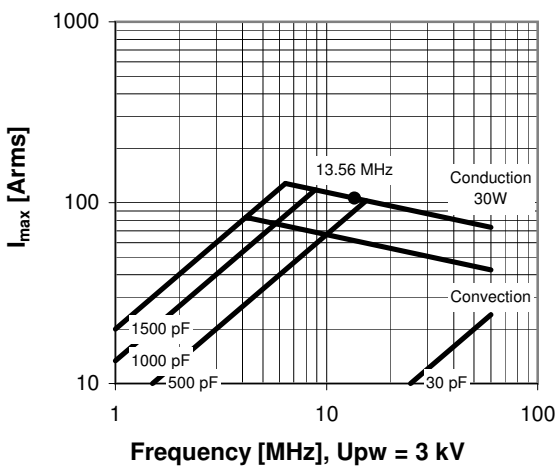

## CVPO-1500BC/5-BECB

Old Type Designation: CV05C-1500PMN

Turns	Nominal Capacitance [pF]	Tolerance
-1.3	30.0	10%
-1.0	36.0	10%
0.0	99.3	0%
2.0	331.3	10%
4.0	565.0	10%
6.0	798.6	10%
8.0	1032.3	10%
10.0	1265.9	10%
12.0	1500.0	10%

Mechanical stop at < 30 pF at ~ -4.4 turns  
Mechanical stop at > 1500 pF at ~ 12.3 turns

Self inductance and resonance frequency

