

CVMX-250AC/25-BEAC-J

Specifications

Capacity C_{max} (nominal)	250 pF
Capacity C_{min} (nominal)	20 pF
Voltage (Peak Test U_{pt} / Peak Working U_{pw})	25 kV / 15 kV
Capacity Tolerance (linear Range)	10%
Max. Current I_{max} at 13.56 MHz with	175 Arms
Conduction Cooling	30 W
Self Inductance	≤ 6 nH
Capacitance per turn	13.4 pF/turn
Torque	≤ 0.6 Nm
Net Weight	2.5 kg

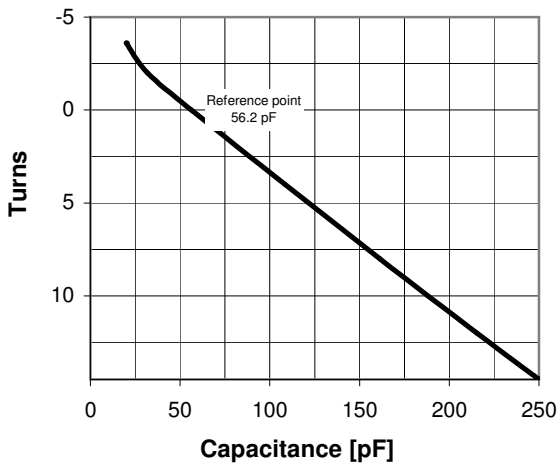
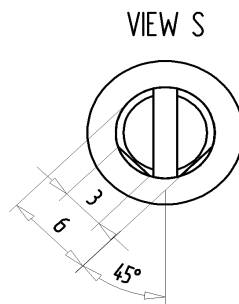
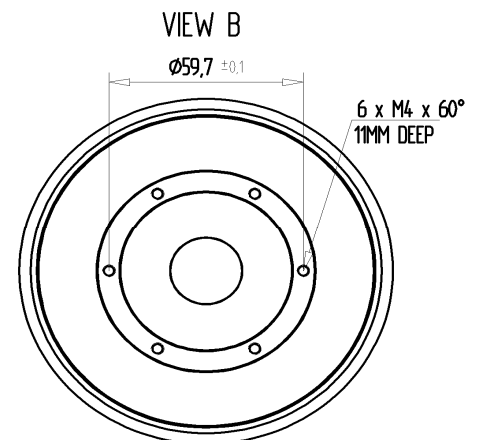
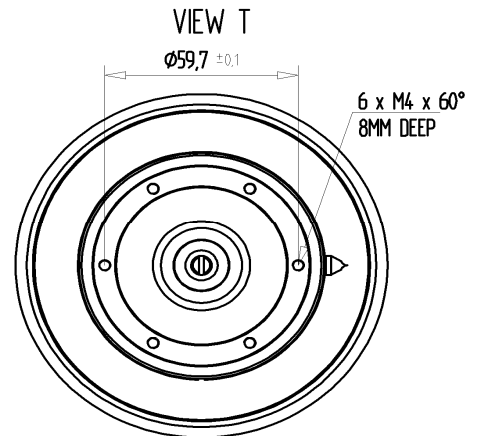

I_{max} at 25°C ambient and 125°C surface temp. for convection and conduction (30 W) cooling

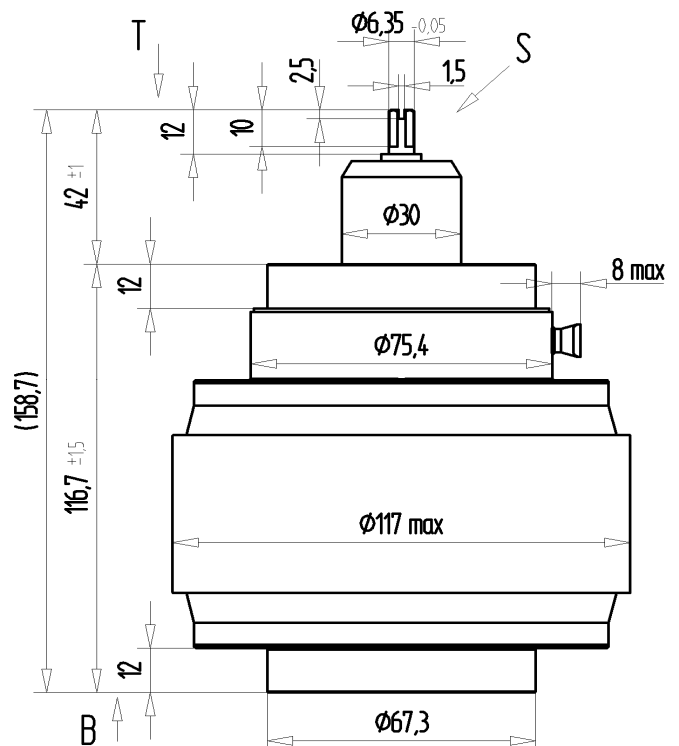
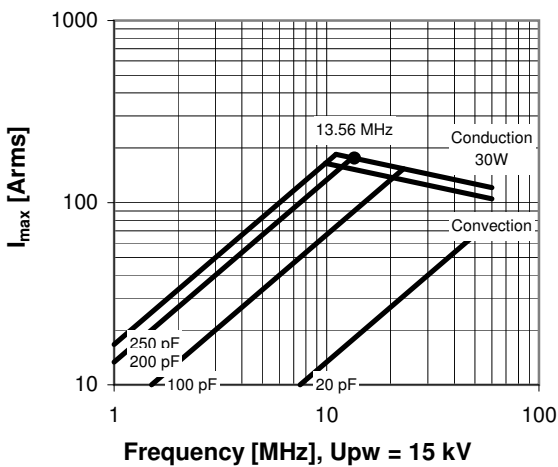

Subject to change without prior notice

Note: Technical information in Service Bulletin SB-52 must be considered

CVMX-250AC/25-BEAC-J

Turns	Nominal Capacitance [pF]	Tolerance
-3.6	20.0	10%
-2.0	31.7	10%
0.0	56.2	0%
4.0	108.3	10%
8.0	161.4	10%
12.0	215.4	10%
14.5	250.0	10%

Mechanical stop at < 20 pF at ~ -10.7 turns
 Mechanical stop at > 250 pF at ~ 14.9 turns

Self inductance and resonance frequency

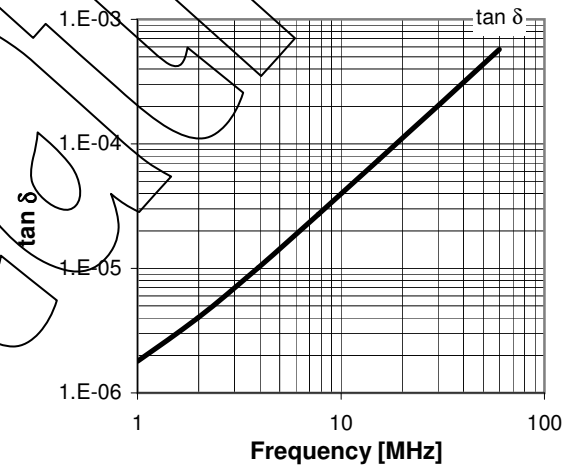
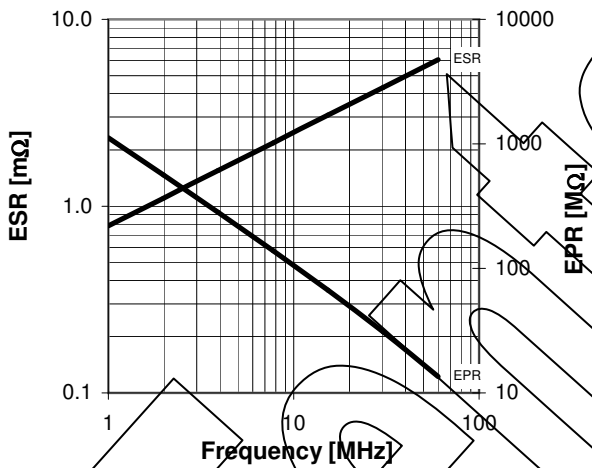
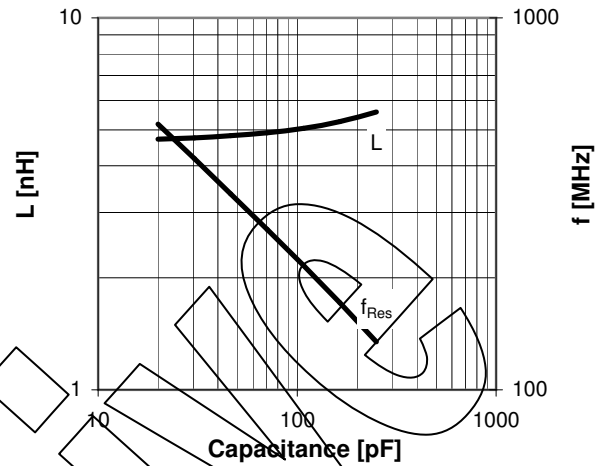

Special Features:

Special Bellows, RoHS Compliant

Subject to change without prior notice

Note: Technical information in Service Bulletin
 SB-52 must be considered